



US 20050112402A1

(19) **United States**

(12) **Patent Application Publication**

Lee et al.

(10) **Pub. No.: US 2005/0112402 A1**

(43) **Pub. Date: May 26, 2005**

(54) **FULL COLOR ORGANIC ELECTROLUMINESCENCE DISPLAY DEVICE**

Publication Classification

(51) **Int. Cl.⁷** **H05B 33/12; H05B 33/10**

(52) **U.S. Cl.** **428/690; 428/917; 428/156; 313/504; 313/506; 427/66**

(76) Inventors: **Jun-Yeob Lee**, Seongnam-si (KR);
Yong-Joong Choi, Yongin-si (KR)

Correspondence Address:
CHRISTIE, PARKER & HALE, LLP
PO BOX 7068
PASADENA, CA 91109-7068 (US)

(57) **ABSTRACT**

Disclosed is a full color organic electroluminescence display device, comprising a substrate; a first electrode; organic film layers including red, green and blue emission layers and an electron transporting layer; and a second electrode. The thickness of the electron transporting layer, which is preferably formed as a common layer, is different in the red and green emission regions from that in the blue emission region so that the device has an excellent purity of color and improved luminous efficiency of red and green colors.

(21) Appl. No.: **10/903,697**

(22) Filed: **Jul. 29, 2004**

(30) **Foreign Application Priority Data**

Nov. 26, 2003 (KR) 2003-84749

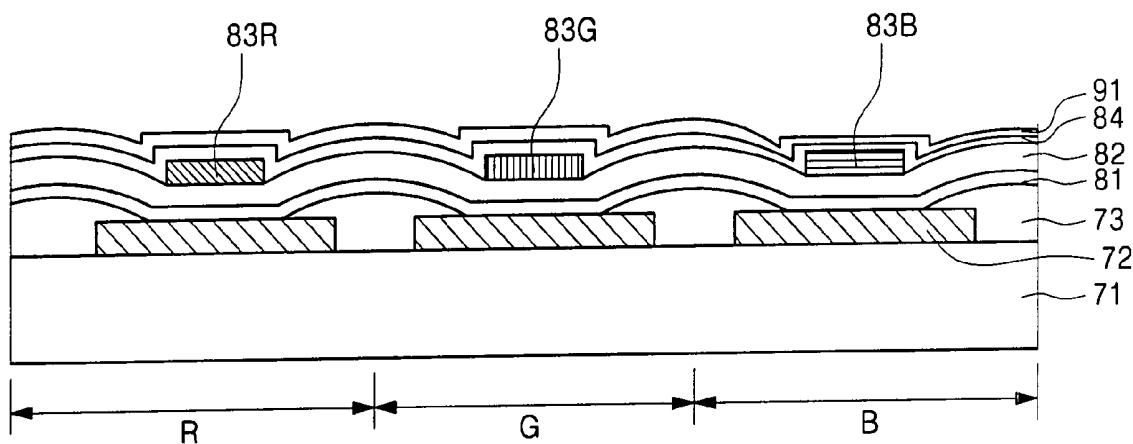

FIG. 1
(PRIOR ART)

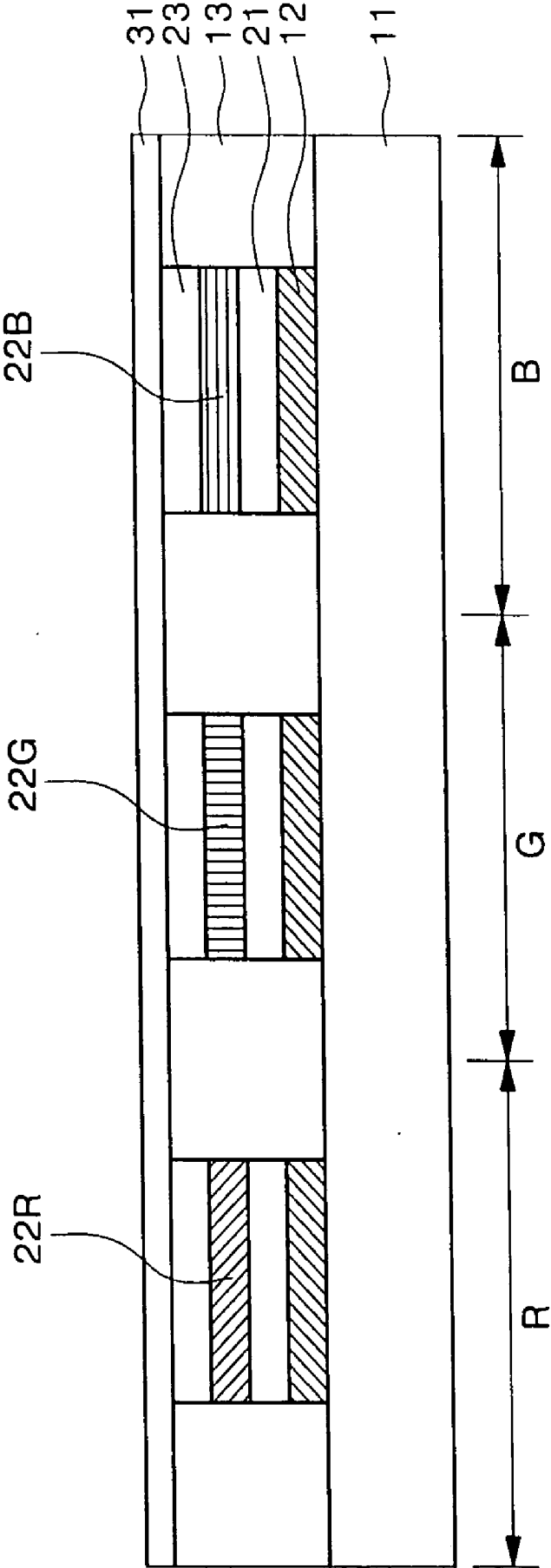

FIG. 2
(PRIOR ART)

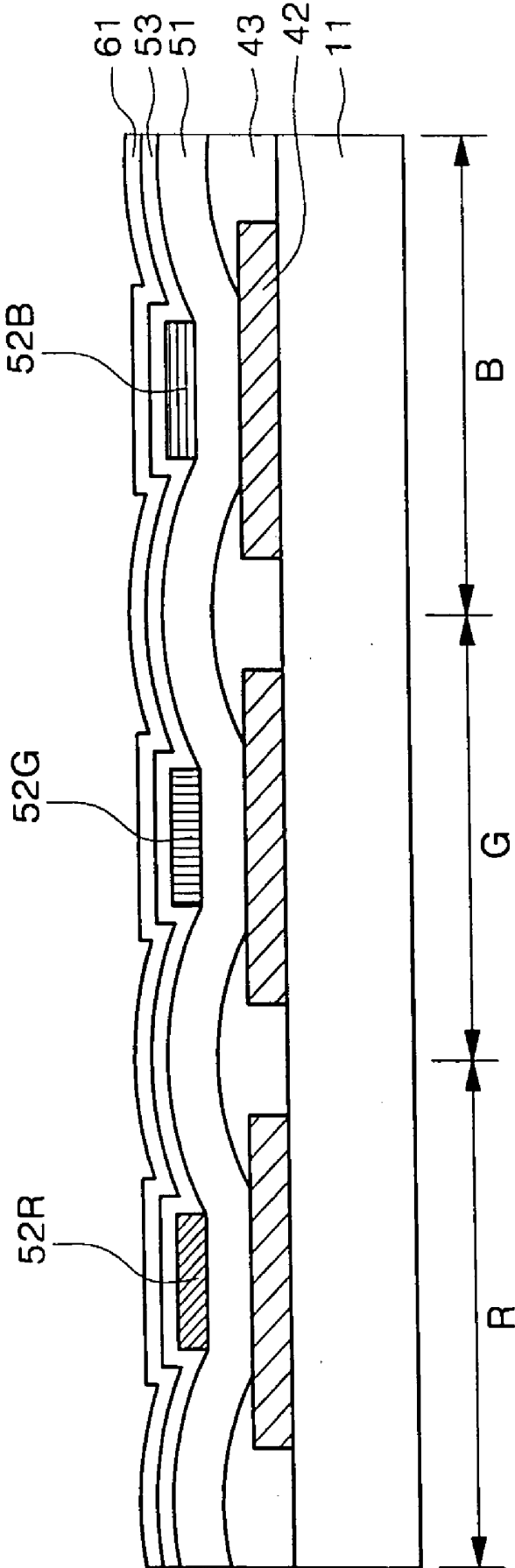

FIG. 3

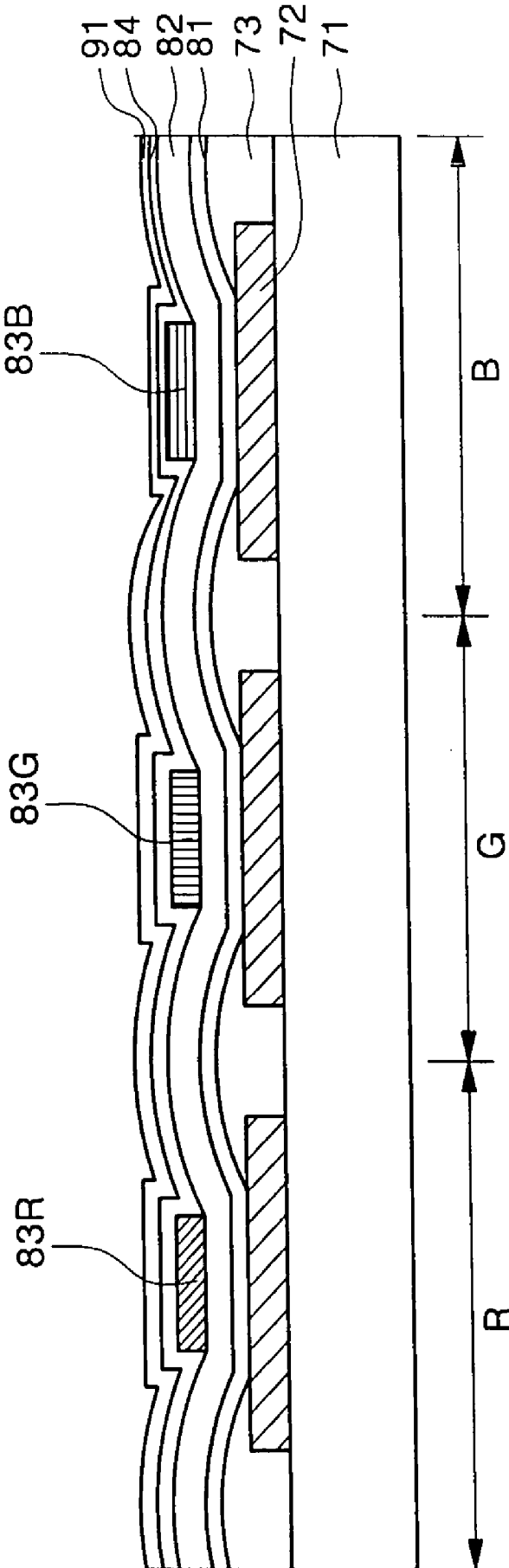

FIG. 4A

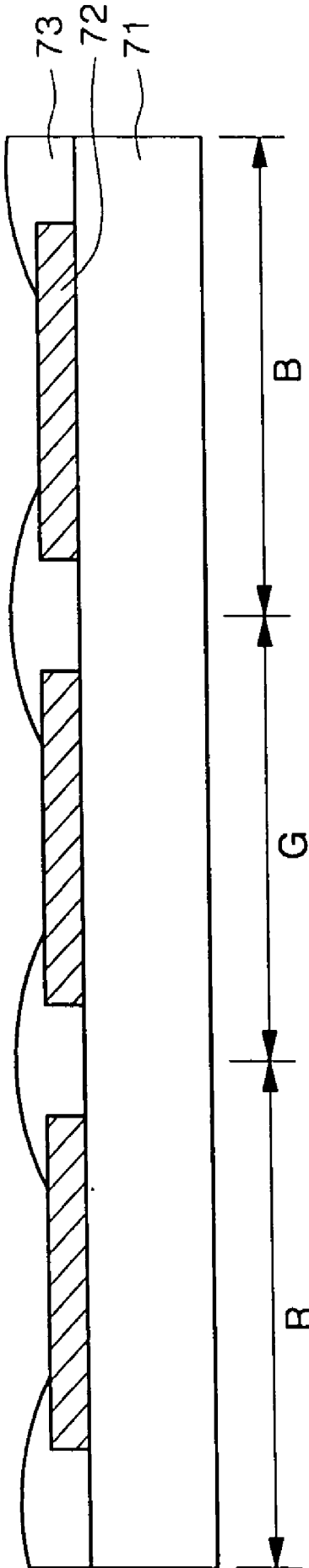

FIG. 4B

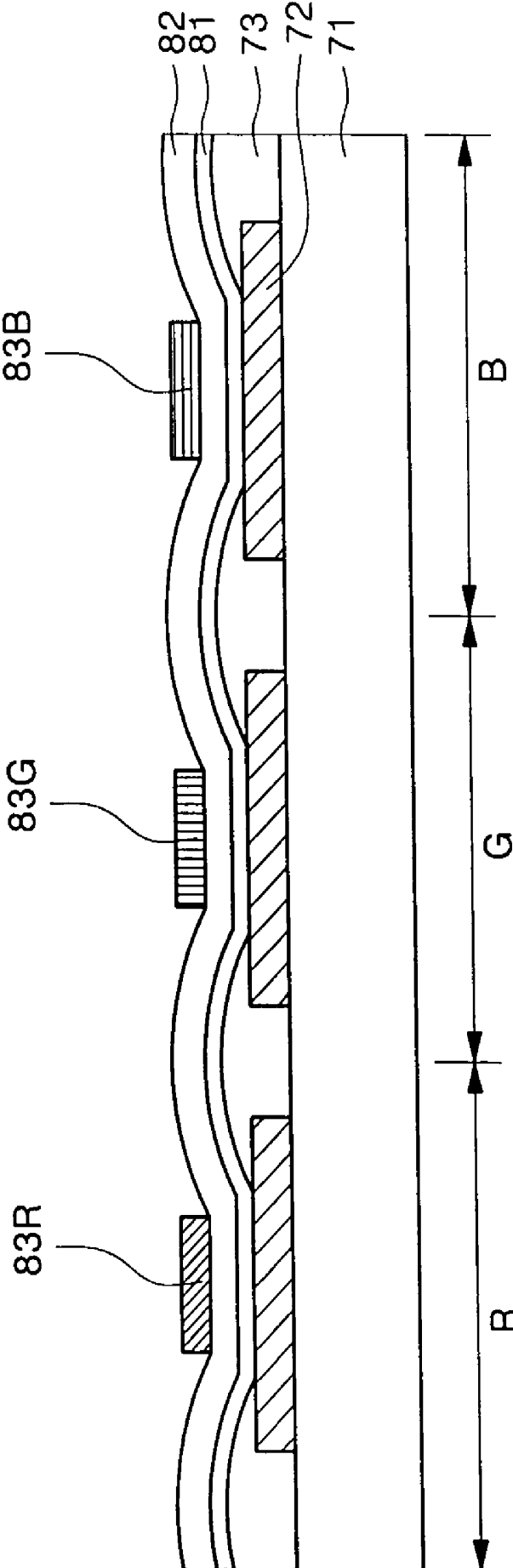

FIG. 4C

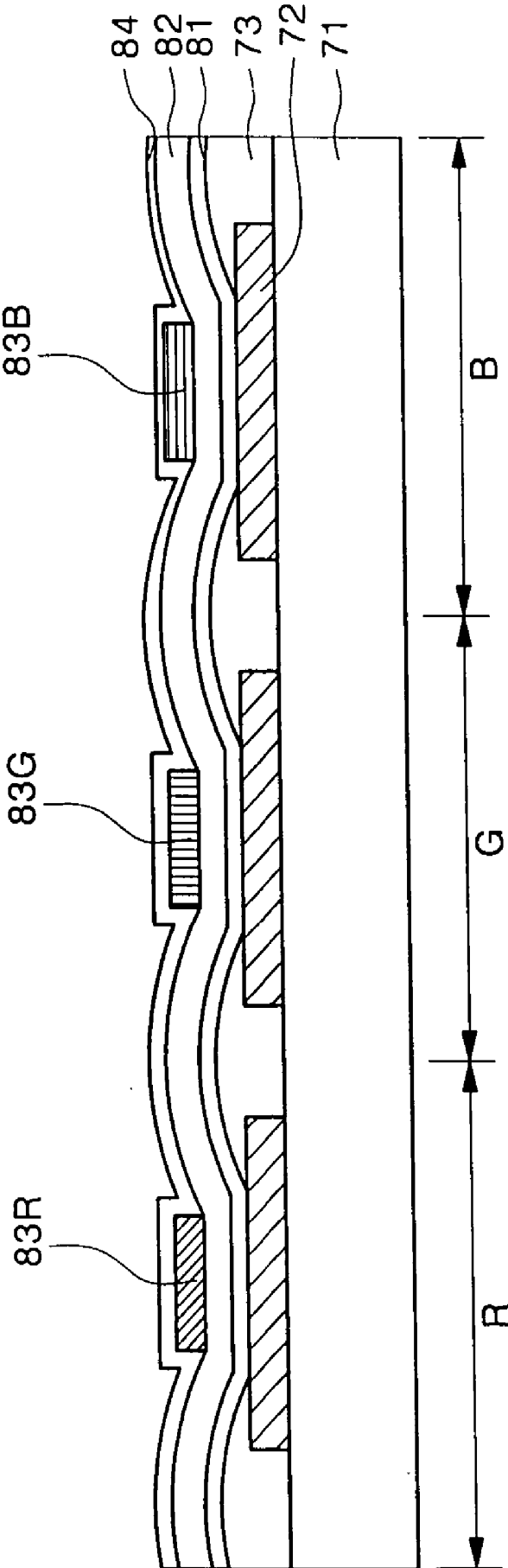
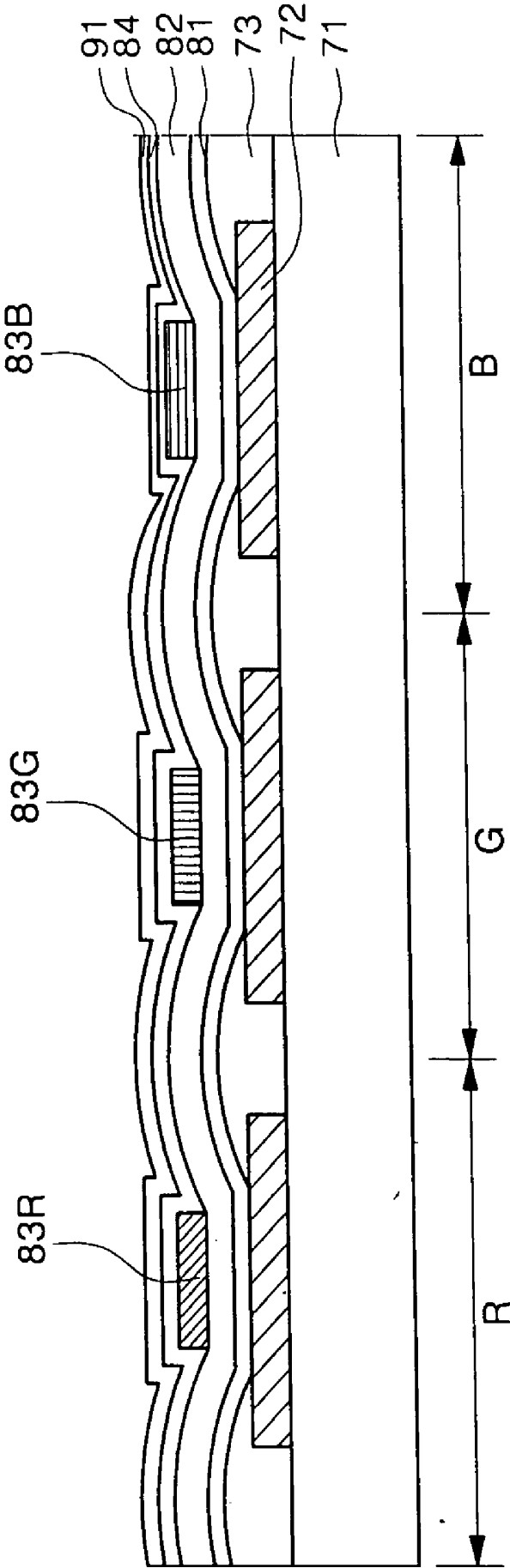

FIG. 4D



FULL COLOR ORGANIC ELECTROLUMINESCENCE DISPLAY DEVICE

CROSS-REFERENCE TO RELATED APPLICATION

[0001] This application claims priority of and the benefit of Korean Patent Application No. 2003-84749, filed on Nov. 26, 2003, the entire disclosure of which is incorporated herein by reference.

BACKGROUND OF THE INVENTION

[0002] 1. Field of the Invention

[0003] The present invention relates to a full color organic electroluminescence display device, wherein an electron transporting layer, which is applied to organic layers as a common layer, is formed with a first thickness in the red and green emission layer regions and with a second thickness, which is different from the first thickness, in the blue emission layer region so that it has a high purity of color, as well as improved red and green color efficiency.

[0004] 2. Description of the Related Art

[0005] In general, an organic electroluminescence display device realizes colors based on the principle that holes and electrons, which are injected from an anode and a cathode, are recombined in an emission layer to emit light. Thus, it has a layered structure having an emission layer inserted between the anode and the cathode. However, such a structure cannot provide high luminous efficiency. Accordingly, an electron injecting layer, an electron transporting layer, a hole transporting layer, a hole injecting layer, and the like are selectively added and inserted between respective electrodes and emission layers.

[0006] Specifically, a full color organic electroluminescence display device has an emission layer, on which red (R), green (G), and blue (B) pixel regions are formed, to implement full color. Although various emission substances have been developed to implement full color, and can exhibit a high purity of color, there have been found few red, green and blue emission substances which are suitable for full color organic electroluminescence display devices and thus, research continues to develop new substances. As a result of research on the structural aspects of organic electroluminescence display devices for implementing full color, it has also been suggested to use a color conversion layer or a color filter in the organic electroluminescence display device.

[0007] However, there has been no organic electroluminescence display device which can implement full color in a fully satisfactory level. This is due to a practical difficulty in forming a fine pattern of an organic thin film, such as an emission layer, an electron injecting layer, and a hole transporting layer, as well as due to difficulty in obtaining the high purity of color due to the differences in luminous efficiency between red, green and blue colors depending on the layers.

[0008] FIG. 1 is a cross-sectional view showing the structure of a conventional full color organic electroluminescence display device.

[0009] Referring to FIG. 1, anode electrodes 12 are deposited and patterned on a substrate 11. The anode electrodes 12 define pixel regions R, G, B using insulating layers 13. As

organic layers, hole transporting layers 21 are formed on the pixel regions R, G, B by, for example, vacuum deposition. Red, green and blue emission substances are deposited on the hole transporting layers 21 and patterned to form red, green and blue emission layers 22R, 22G, 22B. Electron transporting layers 23 are then formed on the red, green and blue emission layers 22R, 22G, 22B. Finally, a cathode electrode 31 is deposited on the entire surface of the substrate to complete a full color organic electroluminescence display device.

[0010] The full color organic electroluminescence display device, as configured above, has a structure in which its anode electrodes 12; hole transporting layers 21; red, green and blue emission layers 22R, 22G, 22B; electron transporting layers 23; and cathode electrode 31 are isolated in respective color regions by the insulating layers 13. To manufacture a full color organic electroluminescence display device with such a structure, however, the hole transporting layers 21 and the electron transporting layers 23 should be separately formed for each respective color through a number of processes.

[0011] In an effort to solve such a problem, U.S. Pat. No. 6,281,634 (the disclosure of which is hereby incorporated herein by reference in its entirety) discloses a method wherein the anodes and the red, green and blue emission layers are separately formed for each respective color, while an electron transporting layer, a hole transporting layer, and a cathode are formed as common layers on the entire surface of the substrate.

[0012] FIG. 2 is a cross-sectional view showing the structure of the full color organic electroluminescence display device disclosed in the above U.S. patent.

[0013] Referring to FIG. 2, the full color organic electroluminescence display device has a structure in which, on a substrate 11, first electrode layers 42, which act as anode electrodes; a hole transporting layer 51; red, green and blue emission layers 52R, 52G, and 52B; an electron transporting layer 53; and a second electrode layer 61, which acts as a cathode electrode, are formed successively. The hole transporting layer 51 and the electron transporting layer 53 are formed as common layers through the entire substrate.

[0014] The full color organic electroluminescence display device, as configured above, is manufactured as follows: the first electrode layers 42 are formed on the substrate 11 through patterning; pixel regions R, G, and B are defined using insulating layers 43; a hole transporting layer 51 is formed as a common layer on the first electrode layers 42 on the entire surface of the substrate; red, green and blue emission layers 52R, 52G, and 52B are patterned and stacked on the hole transporting layer 51; an electron transporting layer 53 is formed as a common layer on the red, green and blue emission layers 52R, 52G, and 52B; and finally a second electrode layer 61 is formed on the entire surface of the substrate. The method disclosed in the above patent is advantageous in that, contrary to conventional methods where the hole transporting layers 21 and the electron transporting layers 23 are formed in an isolated structure, the hole transporting layer 51 and the electron transporting layer 53 are applied as common layers. This simplifies the manufacturing process.

[0015] Such an application of the electron transporting layer 53 as a common layer, however, requires consideration

on the efficiency and chromaticity coordinates of the red, green and blue emission layers **52R**, **52G**, and **52B**. As is known in the industry, an interference phenomenon between light which is directly emitted via the emission layers **52R**, **52G**, and **52B**, and light which is reflected by an electrode, exhibits excellent chromaticity coordinates from an optical point of view when an organic layer has a very small thickness or a specific thickness of 100 nm or more. However, if the electron transporting layer **53** has a large thickness the driving voltage increases, and thus, the optimal thickness for the electron transporting layer for the blue color is fairly thin.

[0016] Such a structure, which is optimized for blue color, is related with the blue emission substance. Specifically, although conventional phosphorescent emission substances may be used for red and green emission, they have too low a luminous efficiency to be used for blue emission and thus cannot be used for a high purity of color. Accordingly, fluorescent substances, which emit light in a manner different from that of the phosphorescent emission substances, are mainly used. A hole blocking layer (not shown) may be formed on the emission layers using a substance, which is similar to the electron transporting layer **53**, to block any movement of holes, so that the full color organic electroluminescence display device, which includes emission layers **52R**, **52G**, and **52B** as shown above, can exhibit high purity of color. If the hole blocking layer is formed on the blue emission substance, however, the blue luminous efficiency is deteriorated. Accordingly, the hole blocking layer should be formed except on the blue emission region B.

[0017] As such, the blue color has difficulty exhibiting high purity of color, unlike the other colors, and is sensitive to the electron transporting layer **53**, which is stacked on the blue emission region B. Accordingly, the thickness of the electron transporting layer **53** of the full color organic electroluminescence display device should be determined in consideration of the blue emission substance. This results in a problem in that it is difficult to design a structure which is both optimized for the red and green emission layers **52R** and **52G**, and to maximize the efficiency characteristics of red and green colors.

[0018] For a full color organic electroluminescence display device with a structure as shown in **FIG. 1**, the electron transporting layers **23** are separately stacked on respective pixel regions R, G, and B. As a result, the device can be optimized for the characteristics of the emission layers **22R**, **22G**, and **22B**. However, in the case of the full color organic electroluminescence display device, which has a structure as shown in **FIG. 2**, the electron transporting layer **53** is stacked as a common layer on respective emission layers **52R**, **52G**, and **52B** with the same thickness. Therefore, the luminous efficiency of each of the emission layers may be deteriorated, due to the thickness of the electron transporting layer **53**.

SUMMARY OF THE INVENTION

[0019] Accordingly, in an embodiment of the present invention, a full color organic electroluminescence display device is provided that exhibits a high purity of color.

[0020] In another embodiment of the present invention, a full color organic electroluminescence display device is provided having improved luminous efficiency of red and green colors.

[0021] In still another embodiment of the present invention, a full color organic electroluminescence display device is provided comprising: a substrate; a first electrode layer formed on the substrate; red, green and blue emission layers formed on the first electrode layer; an electrode transporting layer which is formed on the emission layers on the entire surface of the substrate with a first thickness in the red and green emission regions and a second thickness, different from the first thickness in the blue emission region; and a second electrode layer formed on the electron transporting layer.

[0022] According to an embodiment of the present invention, the electron transporting layer is formed as a common layer on the entire surface of the substrate.

[0023] According to another embodiment of the present invention, the electron transporting layer has a thickness of 30-40 nm in the red and green emission regions and a thickness of 15-30 nm in the blue emission region.

BRIEF DESCRIPTION OF THE DRAWINGS

[0024] The above and other features and advantages of the present invention will become more apparent to those of ordinary skill in the art by describing in detail preferred embodiments thereof with reference to the attached drawings in which:

[0025] **FIG. 1** is a cross-sectional view showing a conventional full color organic electroluminescence display device in which the electron transporting layers are isolated from one another;

[0026] **FIG. 2** is a cross-sectional view showing a conventional full color organic electroluminescence display device in which the electron transporting layer is applied as a common layer;

[0027] **FIG. 3** is a cross-sectional view showing a full color organic electroluminescence display device according to the present invention; and

[0028] **FIGS. 4A** to **4D** are cross-sectional views showing the steps in a method for manufacturing a full color organic electroluminescence display having a structure as in **FIG. 3**.

DETAILED DESCRIPTION OF THE INVENTION

[0029] The present invention will now be described more fully hereinafter with reference to the accompanying drawings, in which preferred embodiments of the invention are shown. This invention may, however, be embodied in different forms and should not be construed as limited to the embodiments set forth herein. Rather, these embodiments are provided so that this disclosure will be thorough and complete, and will fully convey the scope of the invention to those skilled in the art. In the drawings, like numbers refer to like elements throughout the specification.

[0030] **FIG. 3** is a cross-sectional view showing the structure of a full color organic electroluminescence display device according to an embodiment of the present invention.

[0031] Referring to **FIG. 3**, first electrode layers **72**, which act as anode electrodes, are formed and patterned on an insulating substrate **71**, which is made of a material such as silicon oxide (SiO₂), glass, or plastic. Insulating layers **73**

are positioned between the first electrode layers **72** to define respective pixel regions R, G, and B. A hole injecting layer **81** is formed as a common layer over the first electrode layer **72** and a hole transporting layer **82** is formed as a common layer over the hole injecting layer.

[0032] Organic film layers, including red, green and blue emission layers **83R**, **83G**, and **83B** are positioned over the hole transporting layer **82** above the first electrodes corresponding to the R, G, and B pixel regions, respectively. Over the emissions layers is a common electron transporting layer **84**. The electron transporting layer **84** is formed on the entire surface of the substrate as a common layer and has a thickness of 30-40 nm in the red and green regions R, G and a thickness of 15-30 nm in the blue emission region B. If the electron transporting layer **84** has a thickness, in the blue emission region B, that is outside the above range, it is difficult to obtain a desired range for the blue chromaticity coordinate. According to experiments on various effects of modified thicknesses for the electron transporting layer, it has been confirmed that, if the thickness is below 15 nm, the stability of the device is deteriorated and if the thickness is above 30 nm, the chromaticity coordinate thereof are deteriorated. Specifically, if the thickness of the electron transporting layer, according to the present invention, is 20 nm, the chromaticity coordinate is (0.15, 0.15). However, if the thickness is 30 nm, the chromaticity coordinate is (0.15, 0.17) and, if the thickness is 40 nm, the chromaticity coordinate is (0.15, 0.18). This shows the deterioration of the chromaticity coordinate.

[0033] A second electrode layer **91** is then formed on the electron transporting layer **84** on the entire surface of the substrate.

[0034] The first electrode layer **72** is made of a metal film, which is a reflective film, for a top-emitting structure and is made of a material such as ITO or IZO for a transparent electrode for a bottom-emitting structure. The second electrode layer **91** is made of a transparent electrode for a top-emitting structure and for a bottom-emitting structure has a structure wherein a transparent electrode substance is stacked on a metallic substance, which is a reflective film, or on a reflective plate. If the first electrode layer **72** is a cathode electrode, the second electrode layer **91** is an anode electrode and, if the first electrode layer **72** is an anode electrode, the second electrode layer **91** is a cathode electrode layer.

[0035] Furthermore, the organic film layers of the full color organic electroluminescence display device of the present invention may further include a hole injecting layer (HIL) **81**, and a hole transporting layer (HTL) but such layers are not essential. Furthermore, a hole blocking layer (HBL; not shown), and an electron injecting layer (EIL; not shown), may be provided if necessary. When the first electrode layer **72** is the anode electrode, the organic film layers are stacked in the order of: a hole injecting layer; a hole transporting layer **82**; red, green and blue emission layers **83R**, **83G**, **83B**; a hole blocking layer; an electron transporting layer **84**; and an electron injecting layer. When the first electrode layer **72** is the cathode electrode, the organic layers are stacked in the opposite order.

[0036] The full color organic electroluminescence display device according to the present invention, which adapts a structure as mentioned above, can exhibit a high purity of

color and has improved red and green luminous efficiency compared to conventional devices.

[0037] A method for manufacturing of a full color organic electroluminescence display device according to a first embodiment of the present invention will now be described. FIGS. 4A to 4D show a method for manufacturing a full color organic electroluminescence display having the structure shown in FIG. 3, wherein a first electrode layer **72** is an anode electrode and a second electrode layer **91** is a cathode electrode.

[0038] Referring to FIG. 4A, a first electrode layer **72** is formed and patterned on a substrate **71**, which is made of a material such as silicon oxide (SiO₂), glass, or plastic, and an isolating layer **73** is formed thereon to define pixel regions, including red, green and blue pixel regions R, G, and B.

[0039] Referring to FIG. 4B, a hole injecting layer **81** and a hole transporting layer **82** are formed as common layers on the first electrode layer **72** on the entire surface of the substrate **71** and red, green and blue emission substances are patterned on the hole transporting layer **82** to form red, green and blue emission regions **83R**, **83G**, and **83B**.

[0040] The hole injecting layer **81** is commonly made of a low-molecular compound, such as CuPc, TNATA, TCTA, TDAPB, and a high-molecular compound, such as PANI, PEDOT. The hole transporting layer **82** is commonly made of an aryl amine-based, hydrazone-based, stilbene-based, or starburst-based low-molecular compound, such as NPB, TPD, s-TAD, MTADATA, and a carbazole-based, aryl amine-based, perylene-based, or pyrrole-based high-molecular compound, such as PVK. The hole injecting layer **81** and the hole transporting layer **82** are formed using, for example, vacuum deposition or sputtering.

[0041] The red emission substance may be formed of a low-molecular substance, such as Alq₃, CBP, and a PFO-based or PPV-based high-molecular substance. The green emission substance may be formed of a low-molecular substance, such as Alq₃, BGP, and a PFO-based or PPV-based high-molecular substance. The blue emission substance may be formed of substances which are commonly used in the field, for example, a low-molecular substance, such as DPVBi, spiro-DPVBi, spiro-6P, distyrylbenzene (DSB), distyrylarylene (DSA), and a PFO-based, or PPV-based high-molecular substance.

[0042] Referring to FIG. 4C, an electron transporting layer **84** is formed as a common layer on the red, green and blue emission layers **83R**, **83G**, and **83B** on the entire surface of the substrate **71**. Considering the driving voltage, the electron transporting layer **84** has a thickness of 30-40 nm in the red and green emission regions R, G, and a thickness of 15-30 nm in the blue emission region so that respective emission substances can exhibit an appropriate chromaticity coordinate and excellent luminous efficiency.

[0043] The electron transporting layer **84** may be formed using a dry method, such as resistance heating vacuum deposition, electron beam vacuum deposition, or sputtering; a wet method, such as spin coating or dip coating; or a laser transfer method to be formed as a thin film. Here, the dry method is preferred.

[0044] Various methods can be used to differentiate the thickness in respective color regions R, G, and B according

to the present invention. For example, an electron transporting layer **84** is first formed on a blue emission region B with a corresponding thickness, the blue emission region B is then masked, and the electron transporting layer **84** is formed in red and green emission regions R, and G. Alternatively, the blue emission region B is first masked, the electron transporting layer **84** is formed in the red and green emission regions R, and G with a corresponding thickness, the red and green emission regions R, and G are masked, and the electron transporting layer **84** is formed in the blue emission layer with a corresponding thickness. It is also possible to mask the red, green and blue emission regions R, G, and B separately and form the electron transporting layer **84** with different thickness according to the regions.

[0045] As such, if the thickness of electron transporting layer **84** in the red and green emission regions R, and G is different from that in the blue emission region B, it is possible to obtain the same chromaticity coordinates in the red, green and blue emission regions R, G, and B and simultaneously improve the luminous efficiency for the red and green colors, compared with conventional full color organic electroluminescence display devices. As a result of measuring and comparing the chromaticity and luminous efficiency between an experiment example according to the present invention, wherein the electron transporting layer **84** has different thickness in respective color regions R, G, and B, and a comparative example according to the prior art, wherein the electron transporting layer has the same thickness, it has been confirmed that the experiment example has the same chromaticity coordinates as in the comparative example, while the luminous efficiency for the red and green colors thereof is improved.

[0046] The electron transporting layer **84** may be formed of any substance which is commonly used in the field and is not limited in the present invention. For example, an inorganic substance such as LiF and Ca; a quinolinol derivative metal complex such as Alq₃ (tris (8-quinolinol) aluminium); an oxadiazole derivative such as 2,5-bis(1-naphthyl)-1,3,4-oxadiazole (BND) and 2-(4-tert-butylphenyl)-5-(4-biphenyl)-1,3,4-oxadiazole (PBD); or a triazole derivative may be used.

[0047] Referring to FIG. 4D, a second layer **91** is formed as a cathode electrode on the electron transporting layer **84**. After the second electrode layer **91** is deposited, a passivation layer (not shown) is deposited using a sputtering method to complete a full color organic electroluminescence display device. The passivation layer is preferably made of a transparent inorganic substance, such as SiO₂ or Y₂O₃.

[0048] The organic film layers may additionally include a hole blocking layer and/or an electron injecting layer between the red, green and blue emission layers **83R**, **83G**, and **83B** and the second electrode layer **91**, if necessary. The respective layers may be formed of conventional substances. For example, the hole blocking layer may be formed of a low-molecular weight substance, such as Alq₃, BCP, CF-X, or TAZ, spiro-TAZ, and the electron injecting layer may be formed of a low-molecular weight substance, such as Alq₃, Ga complex, PBD, or an oxadiazole-based high-molecular weight substance. The layers can be formed using commonly used coating methods, such as spin coating or dip coating; an extrusion, spin, or knife coating method; or a deposition method, such as a vacuum deposition method or a chemical vapor deposition method.

[0049] The full color organic electroluminescence display device manufactured by the above method according to the present invention has an electron transporting layer **84**, which has a first thickness in the red and green emission regions R and G and a second thickness, which is different from the first thickness, in a blue emission region B, so that it has improved luminous efficiency for red and green colors compared with conventional devices, while having the same chromaticity coordinates.

[0050] In the above embodiment of the full color organic electroluminescence display device, the first electrode layer **71** is an anode electrode and the second electrode layer **91** is a cathode layer. For an embodiment wherein the first electrode layer **71** is a cathode electrode and the second electrode layer **91** is an anode layer, the organic layers are formed in the opposite order.

[0051] Specifically, when the organic film layers include a hole injecting layer, a hole transporting layer, a hole blocking layer, and an electron transporting layer, and first electrode layer **71** is a cathode layer, the hole blocking layer and the electron injecting layer are stacked between the first electrode layer and the emission layer and the hole injecting layer and the hole transporting layer are stacked between the emission layer and the second electrode.

[0052] Such a structure may be suitably applied to an active matrix organic electroluminescence display device including a thin film transistor, as well as to a passive matrix organic electroluminescence display device including no thin film transistor.

[0053] A preferred example of the present invention will now be presented. However, the example is only for better understanding the present invention and the present invention is not limited by the example in any way.

[0054] The full color organic electroluminescence display devices, which are manufactured in the following experimental example and comparative example, are bottom-emitting full color organic electroluminescence display devices and have a first electrode, which is a transparent electrode, and a second electrode, which is a reflective electrode. Between the first and second electrodes, a hole injecting layer; a hole transporting layer; red, green and blue emission layers; a hole blocking layer; and an electron transporting layer are stacked successively.

EXAMPLE

[0055] Initially, ITO was formed on a prepared glass substrate and patterned to form a first electrode layer.

[0056] Then, copper phthalocyanine (CuPc) was deposited to a thickness of 10 nm in a vacuum of 10⁻⁶ torr to form a hole injecting layer.

[0057] Subsequently, N,N'-di(1-naphthyl)-N,N'-diphenylbenzidine (NPD) was deposited on the hole injecting layer to a thickness of 50 nm in a vacuum of 10⁻⁶ torr to form a hole transporting layer.

[0058] Subsequently, 10% tris(1-phenylquinoline) iridium in carbazole biphenyl was deposited in a red emission region on the hole transporting layer to form a red emission layer with a thickness of 30 nm.

[0059] Then, 5% tris(2-phenylpyridine) iridium was deposited in a green emission region on the hole transporting layer to form a green emission layer with a thickness of 30 nm.

[0060] Next, a host/dopant of 5% distyrylanthracene/anthracenediphenylamine was deposited in a blue emission region to form a blue emission layer with a thickness of 30 nm.

[0061] After the red, green and blue emission layers were formed, a hole blocking layer was deposited as a common layer on the emission layers under a vacuum of 10^{-6} torr to a thickness of 5 nm using biphenoxy-bi(8-quinolinolato)aluminium (BALq).

[0062] Next, an electron transporting layer was deposited on the hole blocking layer using tris(8-quinolinolato)Aluminium (Alq) under a vacuum of 10^{-6} torr with a thickness of 40 nm in the red and green emission regions and with a thickness of 20 nm in the blue emission region.

[0063] After the electron transporting layer was deposited, an electron injecting layer was deposited to a thickness of 1 nm using LiF and Al as a reflective layer was deposited on the electron injecting layer to a thickness of 300 nm to form a second electrode. Finally, the upper portion of the second electrode was encapsulated by a metal can and barium oxide to complete a test cell.

COMPARATIVE EXAMPLE

[0064] The Comparative Example was manufactured by the same method as the Example, except that the electron transporting layer had a constant thickness.

[0065] Initially, ITO was formed on a prepared glass substrate and patterned to form a first electrode layer.

[0066] Then, copper phthalocyanine (CuPc) was deposited to a thickness of 10 nm under a vacuum of 10^{-6} torr to form a hole injecting layer.

[0067] Subsequently, N,N'-di(1-naphthyl)-N,N'-diphenylbenzidine (NPD) was deposited on the hole injecting layer to a thickness of 50 nm under a vacuum of 10^{-6} torr to form a hole transporting layer.

[0068] Subsequently, 10% tris(1-phenylquinoline) iridium in carbazole biphenyl was deposited in a red emission region on the hole transporting layer to form a red emission layer with a thickness of 30 nm.

[0069] Then, 5% tris(2-phenylpyridine) iridium was deposited in a green emission region on the hole transporting layer to form a green emission layer with a thickness of 30 nm.

[0070] Next, a host/dopant of 5% distyrylanthracene/anthracenediphenylamine was deposited in a blue emission region on the hole transporting layer to form a blue emission layer with a thickness of 30 nm.

[0071] After the red, green and blue emission layers were formed, a hole blocking layer was deposited as a common layer on the emission layers under a vacuum of 10^{-6} torr to a thickness of 5 nm using biphenoxy-bi(8-quinolinolato)aluminium (BALq).

[0072] Next, an electron transporting layer was deposited to a thickness of 20 nm on the red, green and blue pixel regions using tris(8-quinolinolato)Aluminium (Alq) under a vacuum of 10^{-6} torr.

[0073] After the electron transporting layer was deposited, an electron injecting layer was deposited to a thickness of 1

nm using LiF and a reflective electrode was deposited on the electron injecting layer to a thickness of 300 nm using Al to form a second electrode. Finally, the upper portion of the second electrode was encapsulated by a metal can and barium oxide to complete a test cell.

[0074] Test

[0075] Efficiency in respective emission regions, driving voltage, and chromaticity coordinates of each of the test cells of the Example and the Comparative Example, were measured and are provided in Table 1 below.

TABLE 1

	Example			Comparative Example		
	R	G	B	R	G	B
Efficiency (cd/R)	12	29.5	5.5	9	25	5.5
Driving voltage (V) (500 cd/m ²)	7.1	6.8	6.5	6.9	6.5	6.5
Chromaticity CIEx	0.62	0.29	0.15	0.62	0.29	0.15
coordinates CIEy	0.37	0.63	0.13	0.37	0.63	0.13

[0076] Comparing the Example with the Comparative Example, based on the above table, it is clear that they have the same blue luminous efficiency. This means that the thickness of the electron transporting layer, as suggested by the present invention, is appropriate. In addition, the red luminous efficiency is 12 in the case of Example and 9 in the case of Comparative Example. This means that the efficiency is improved by about 33% by setting the thickness of the electron transporting layer. The green luminous efficiency is 29.5 in the former case and 25 in the latter case, which also means that the efficiency is improved by about 18%.

[0077] Meanwhile, although the driving voltage values of the red and green emission layers of Example are slightly larger than those of the Comparative Example, this difference can be neglected.

[0078] In addition, the measurements of chromaticity coordinates show that the red color, the green color, and particularly the blue color, which is sensitive to the thickness of the electron transporting layer, have the same chromaticity coordinates between the Example and the Comparative Example.

[0079] As a result of the above experiment, it has been confirmed that, although the thickness of the electron transporting layer in the red and green emission regions is different from that in the blue emission region, for the present invention, it is still possible to improve the efficiency, compared with the prior art, while obtaining the same chromaticity coordinates.

[0080] As mentioned above, the thickness of the electron transporting layer, which is applied as a common layer, has different thickness in respective emission regions in the full color organic electroluminescence display device of the present invention. This maximizes the efficiency of red, green and blue emission layers. Therefore, it is possible to improve the luminous efficiency of red and green colors, compared with conventional devices, while obtaining the same chromaticity coordinates.

[0081] Although a preferred embodiment of the present invention has been described for illustrative purposes, it is

apparent to those skilled in the art that various modifications, additions and substitutions are possible, without departing from the scope and spirit of the invention as disclosed in the accompanying claims.

What is claimed is:

1. A full color organic electroluminescence display device, comprising:

a substrate;

a first electrode layer formed on the substrate;

red, green and blue emission layers formed on the first electrode layer;

an electrode transporting layer which is formed on the emission layers on an entire surface of the substrate and has a first thickness in the red and green emission regions and a second thickness, which is different from the first thickness, in the blue emission region; and

a second electrode layer formed on the electron transporting layer.

2. The full color organic electroluminescence display device as claimed in claim 1, wherein the electrode transporting layer has a thickness of between 30 and 40 nm in the red and green emission regions and a thickness of between 15 and 30 nm in the blue emission region.

3. The full color organic electroluminescence display device as claimed in claim 1, wherein the electron transporting layer is formed as a common layer on the entire surface of the substrate.

4. The full color organic electroluminescence display device as claimed in claim 1, wherein the electron transporting layer is formed of a material selected from the group consisting of inorganic substances of LiF and Ca;

a quinolinol derivative metal; an oxadiazole derivative; and

a triazole derivative.

5. The full color organic electroluminescence display device as claimed in claim 1, wherein the electron transporting layer is formed by a method selected from the group consisting of a dry method of resistance heating vacuum deposition, an electron beam vacuum deposition method, and a sputtering method; a wet method of spin coating, dip coating, and inkjet type; and a laser transfer method.

6. The full color organic electroluminescence display device as claimed in claim 1, wherein the electron transporting layer is formed using a dry method.

7. The full color organic electroluminescence display device as claimed in claim 1, wherein one of the first and second electrode layers is selected from the group consisting of a cathode electrode and an anode electrode.

8. The full color organic electroluminescence display device as claimed in claim 1, wherein one of the first and second electrode layers is selected from the group consisting of a reflective electrode and a transparent electrode.

9. The full color organic electroluminescence display device as claimed in claim 1, further comprising at least one layer selected from the group consisting of a hole injecting layer, a hole transporting layer, a hole blocking layer, and an electron injecting layer between the first and second electrode layers.

10. A method for manufacturing a full color organic electroluminescence display device, the method comprising the steps of:

forming first electrodes on a substrate;

defining pixel regions and forming an insulating layer between the first electrodes so as to be partly superimposed on both ends of each first electrode and to have emission regions opened;

stacking red, green and blue emission regions of pixel regions using respective emission substances and patterning the emission substances to form emission layers;

forming an electron transporting layer on an entire surface of the substrate, the electron transporting layer having a first thickness in the red and green emission regions and a second thickness, which is different from the first thickness, in the blue emission region; and

forming a second electrode on the electron transporting layer.

11. The method as claimed in claim 10, wherein the electron transporting layer has a thickness of between 30 and 40 nm in the red and green emission regions and a thickness of between 15 and 30 nm in the blue emission region.

12. The method as claimed in claim 10, wherein the electron transporting layer is formed on the entire surface of the substrate as a common layer.

13. The method as claimed in claim 10, wherein the electron transporting layer is formed by a method selected from the group consisting of a dry method of resistance heating vacuum deposition, an electron beam vacuum deposition method, and a sputtering method; a wet method of spin coating, dip coating, and inkjet type; and a laser transfer method.

14. The method as claimed in claim 13, wherein the electron transporting layer is formed with a dry method.

15. The method as claimed in claim 10, wherein the electron transporting layer is formed by a method selected from the group consisting of:

a method wherein the electron transporting layer is formed on the blue emission region, the blue emission region is masked, and the electron transporting layer is formed in the red and green emission regions;

a method wherein the blue emission region is masked, the electron transporting layer is formed on the red and green emission regions, the red and green emission regions are masked, and the electron transporting layer is formed on the blue emission region; and

a method wherein the red, green and blue emission regions are masked separately and the electron transporting layer is formed on the regions independently.

16. The method as claimed in claim 10, wherein at least one layer is additionally formed between the first and second electrode layers, the layer being selected from the group consisting of a hole injecting layer, a hole transporting layer, a hole blocking layer, and an electron injecting layer.

专利名称(译)	全彩有机电致发光显示装置		
公开(公告)号	US20050112402A1	公开(公告)日	2005-05-26
申请号	US10/903697	申请日	2004-07-29
[标]申请(专利权)人(译)	李准YEOB 崔勇JOONG		
申请(专利权)人(译)	李准YEOB 崔容JOONG		
当前申请(专利权)人(译)	三星DISPLAY CO. , LTD.		
[标]发明人	LEE JUN YEOB CHOI YONG JOONG		
发明人	LEE, JUN-YEOB CHOI, YONG-JOONG		
IPC分类号	H05B33/26 H01L27/32 H01L51/00 H01L51/50 H05B33/10 H05B33/12		
CPC分类号	H01L27/3211 H01L51/0059 H01L51/0062 H01L51/0078 H01L51/0081 Y10S428/917 H01L51/5048 H01L51/5096 H01L2251/558 Y10T428/24479 H01L51/0085		
优先权	1020030084749 2003-11-26 KR		
其他公开文献	US7833633		
外部链接	Espacenet USPTO		

摘要(译)

公开了一种全彩色有机电致发光显示装置，包括基板；第一电极；有机薄膜层包括红色，绿色和蓝色发光层和电子传输层；和第二个电极。优选形成公共层的电子传输层的厚度在红色和绿色发射区域中与在蓝色发射区域中的厚度不同，使得该器件具有优异的颜色纯度和改善的红色发光效率。绿色。

